

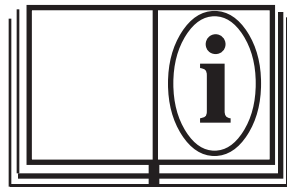

Tube Squaring Machine

Model TSE 1.0



	TUBE & PIPE	CE
SQUARING MACHINES		
Mod. TSE	Ser.No. <input style="width: 15px; height: 15px;" type="text"/> <input style="width: 15px; height: 15px;" type="text"/> <input style="width: 15px; height: 15px;" type="text"/> <input style="width: 15px; height: 15px;" type="text"/> <input style="width: 15px; height: 15px;" type="text"/> <input style="width: 15px; height: 15px;" type="text"/>	
E.H. WACHS COMPANIES 100 Shepard St. Wheeling Il. 60090 ——— Patent Pending ———		

Part Number: 18-MAN-01

Revision No: 2



3 rd Printing:
Nov. '97

TSE TUBE SQUARING MACHINE

TABLE OF CONTENTS

SECTION I.	STANDARD EQUIPMENT	1
SECTION II.	SAFETY	2-5
SECTION III.	CE DECLARATION OF CONFORMITY	6
SECTION IV.	MACHINE SPECIFICATIONS	7
SECTION V.	SET UP & OPERATING PROCEDURES	8-10
SECTION VI.	MAINTENANCE	10
SECTION VII.	OPERATIONAL CHARTS & GRAPHS	11
SECTION VIII.	TROUBLE SHOOTING	12
SECTION IX.	PARTS LISTS & EXPLODED VIEW DRAWINGS	13-15
SECTION X.	ORDERING INFORMATION	16

TSE TUBE SQUARING MACHINE

SECTION I

TSE STANDARD EQUIPMENT



- TSE 1.0 with drive motor and cord
- "T" handle allen wrench
- 1 Tool bit
- Operating Instruction Manual
- Shipping Case

TSE TUBE SQUARING MACHINE

SECTION II

TSE 1.0 SAFETY INSTRUCTIONS

Since 1883, EH Wachs has built a reputation for quality and a commitment to consumer satisfaction. In accordance with this, Wachs must take on the added responsibility of doing our best to assure the safest use of our equipment.

We have assembled a list of safety reminders to aid in creating the safest possible working environment. We recommend that the precautionary steps listed there be closely observed.



**Read the Following thoroughly
before proceeding**

1. **READ THE OPERATING MANUAL!!**

Reading the setup and operating instructions prior to beginning the setup procedures can save valuable time and help prevent injury to operators or damage to machines.

2. **INSPECT MACHINE & ACCESSORIES!**

Prior to machine setup physically inspect the machine and it's accessories. Look for worn tool slides, loose bolts or nuts, lubricant leakage, excessive rust, etc. A properly maintained machine can greatly decrease the chances for injury.

3. **ALWAYS READ PLACARDS & LABELS!**

All placards, labels and stickers must be clearly legible and in good condition. Replacement labels can be purchased from the manufacturer.

4. **KEEP CLEAR OF ROTATING PARTS!**

Keep hands, arms and fingers clear of all rotating or moving parts. Always turn machine off before attempting any adjustments requiring contact with the machine or it's accessories.

5. **SECURE LOOSE CLOTHING & JEWELRY!**

Loose fitting clothing, jewelry; long, unbound hair can get caught in the rotating parts on machines. By keeping these things secure or removing them you can greatly reduce the chance for injury.

6. **KEEP WORK AREA CLEAR!**

Be sure to keep the work area free of clutter and nonessential materials. Only allow those personnel directly associated with the work being performed to have access to the area if possible.

ALWAYS WEAR PROTECTIVE EQUIPMENT:

	WARNING Impact resistant eye protection must be worn while operating or working near this tool.
--	---

	CAUTION Personal hearing protection is required at all times when operating or working near this tool.
---	--

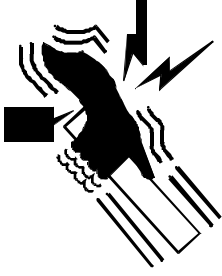
	CAUTION Some individuals are susceptible to disorders of the hands and arms when exposed to tasks which involve highly repetitive motions and/or vibration. Disorders such as Carpal tunnel syndrome and tendonitis can be caused or aggravated by repetitious, forceful exertions of the hands and arms.
--	---

SICHERHEITSVORSCHRIFTEN

D

Seit 1883 hat EH Wachs seinen Ruf für Qualität und Zufriedenstellung seiner Kunden aufgebaut. Wachs übernimmt demgemäß die zusätzliche Verantwortung, sein Bestes zu tun, einen möglichst sicheren Umgang mit seiner Ausrüstung zu gewährleisten, und hat daher eine Liste von Sicherheits-Gedächtnisstützen zusammengestellt, die den Kunden in der Erschaffung einer möglichst sicheren Arbeitsumgebung zu unterstützen. Wir empfehlen, die aufgeführten Vorsichtsmaßnahmen genau zu beachten.



BITTE NACHFOLGENDES SORGFÄLTIG VOR DEM FORTFAHREN DURCHLESEN !

1. DIE BETRIEBSANLEITUNG LESEN!

Bedienungsmänner können wertvolle Zeit einsparen und Verletzungen und Beschädigungen der Maschine vermeiden, wenn Sie die Aufbau- und Betriebsanleitungen vor dem Aufbau durchlesen.

2. MASCHINE UND ZUSATZGERÄTE ÜBERPRÜFEN!

Vor dem Aufbau der Maschine sollte diese und die Zusatzgeräte physisch überprüft werden. Prüfen Sie, ob abgenutzte Werkzeugschlitzen, lockere Bolzen und Schraubenmütter, Schmiermittelgänge, übermäßiger Rost, usw. bestehen. Mit einer ordnungsgemäß gewarteten Maschine kann die Wahrscheinlichkeit eines Unfall stark verringert werden.

3. IMMER INFORMATIONEN UND ETIKETTEN LESEN!

Alle Informationen, Etiketten und Aufkleber müssen gut lesbar und in gutem Zustand sein. Vom Hersteller können Ersatzetiketten angefordert werden.

4. BLEIBEN SIE ROTIERENDEN TEILEN FERN!

Die Hände, Arme und Finger sollten von allen sich drehenden Teilen ferngehalten werden. Vor der Durchführung von Nachstellungen, die Sie in Berührung mit der Maschine oder deren Zusatzgeräte bringen, die Maschine stets abschalten!

5. WEITE KLEIDUNG UND SCHMUCK BEFESTIGEN!

Weite Kleidung, Schmuck und lange, nicht gelöstes Haar können in den rotierenden Teilen der Maschine hängenbleiben. Die Wahrscheinlichkeit einer Verletzung kann stark herabgesetzt werden, wenn Sie diese Dinge befestigen bzw. abnehmen.

6. ARBEITSBEREICH FREIHALTEN!

Stets darauf achten, daß sich keine unnötigen Materialien, usw. im Arbeitsbereich befinden. Nur dem direkt mit der zu leistenden Arbeit in Zusammenhang stehenden Personal Zugang zum Arbeitsbereich gestatten!

STETS SCHUTZAUSRÜSTUNG TRAGEN!

	WARNUNG! Schlagbiegegeste Augenschutzbrillen müssen stets bei Betrieb dieses Werkzeugs oder in der Nähe dieses Werkzeugs getragen werden.
--	---

	ACHTUNG! Ein Ohrschutz muß stets bei Betrieb dieses Werkzeugs oder in der Nähe dieses Werkzeugs getragen werden.
--	--

	ACHTUNG! Manche Personen leiden an Funktionsstörungen der Hände und Arme, wenn sie sich dauernd wiederholende Aufgaben auszuführen haben, die andauernde Bewegungen und/oder Schwingungen mit sich führen. Funktionsstörungen, wie beispielsweise Handwurzels- und Sehnenentzündungen, können durch eine sich wiederholende und mit viel Kraft ausgeübte Anwendung der Hände und Arme entweder hervorgerufen oder verschlimmert werden.
--	---

CONSIGNE DE SÉCURITÉ

F

Depuis 1883, la société EH Wachs a bâti sa réputation sur la qualité de ses produits et son engagement à satisfaire la clientèle. Conformément à ces principes, Wachs se doit également d'être aussi responsable pour faire de son mieux afin d'assurer l'utilisation la plus sûre de son matériel. Nous avons réuni une liste de rappels de sécurité pour aider à créer un cadre de travail aussi sûr que possible. Nous vous recommandons d'observer scrupuleusement les vérifications préalables indiquées ci-dessous.



Lisez ce qui suit avant d'aller plus avant

1. LIRE LE MANUEL D'UTILISATION !!

En lisant les instructions de réglage et de fonctionnement avant de commencer les procédures de réglage, vous pourrez économiser un temps précieux et vous éviterez aux machinistes de se blesser et d'abîmer les machines.

2. INSPECTER LA MACHINE ET LES ACCESSOIRES !

Avant de régler la machine, inspectez-la à l'oeil nu ainsi que ses accessoires. Recherchez les outils couillants usagés, les boulons ou les écrous desserrés, les fuites de lubrifiant, les dépôts de rouille excessifs, etc. Avec une maintenance adéquate, vous diminuerez sensiblement les risques d'accidents.

3. LIRE SYSTÉMATIQUEMENT LES AFFICHES ET ÉTIQUETTES !

Toutes les affiches, étiquettes et autocollants doivent être parfaitement lisibles et en bon état. Vous pouvez acheter de nouvelles étiquettes auprès du fabricant.

4. SE TENIR À DISTANCE DES PIÈCES ROTATIVES !

Tenez vos mains, bras et doigts éloignés de toutes pièces rotatives ou mobiles. Arrêtez toujours la machine avant de tenter de procéder au moindre réglage nécessitant un contact avec la machine ou ses accessoires.

5. PRENDRE GARDE AUX VÊTEMENTS AMPLES ET AUX BIJOUX !

Les vêtements amples, les bijoux, et les cheveux longs qui ne sont pas attachés peuvent être pris dans les pièces rotatives des machines. Enlevez ou attachez ce qui gêne de façon à réduire au maximum les risques d'accident.

6. CONSERVER UNE AIRE DE TRAVAIL DÉGAGÉE !

Ayez bien soin d'enlever les débris et les matériaux qui ne sont pas indispensables. N'autorisez que la présence des employés chargés du travail en cours d'exécution pour dégager au mieux l'aire de travail.

PORTER TOUJOURS UN ÉQUIPEMENT DE PROTECTION

	AVERTISSEMENT Protégez vos yeux avec des lunettes de sécurité antichoc lorsque cet outil est en marche ou si vous travaillez à proximité.
--	---

	ATTENTION Il est absolument indispensable de vous protéger contre les oreilles lorsque cet outil est en marche ou si vous travaillez à proximité.
--	---

	ATTENTION Certaines personnes sont particulièrement sujettes aux troubles articulaires des mains et des bras lorsqu'elles sont soumises à des tâches nécessitant des gestes très répétitifs ou lorsqu'elles sont exposées à des vibrations. Le syndrome du canal carpien et les tendinites peuvent résulter ou être aggravés par des efforts rigoureux des bras et des mains.
--	---

INSTRUCCIONES DE SEGURIDAD

E

Desde 1883, EH Wachs ha ido forjando una reputación de calidad y compromiso hacia la satisfacción del cliente. De acuerdo con esto, Wachs debe aceptar la responsabilidad adicional de hacer todo lo posible para asegurar el uso seguro de nuestros equipos. Hemos reunido una lista de recordatorios de seguridad para ayudarle a crear el ambiente de trabajo más seguro posible. Recomendamos que observe cuidadosamente los pasos de precaución enumerados en la misma.



Lea lo siguiente detenidamente antes de proceder

1. ¡ LEA EL MANUAL DE OPERACIONES!

La lectura de las instrucciones de instalación y operación antes de comenzar los procedimientos de instalación puede ahorrarle tiempo valioso y ayudarle a evitar daños a operarios o daño a las máquinas.

2. ¡ INSPECCIONA LA MAQUINA Y LOS ACCESORIOS!

Antes de la instalación de la máquina inspeccione físicamente la máquina y sus accesorios. Busque muescas de herramientas usadas, pernos o tuercas flojas, fugas de lubricante, excesiva corrosión, etc. Una máquina mantenida adecuadamente puede disminuir grandemente las ocasiones de daños.

3. ¡ LEA SIEMPRE LOS LETREROS Y ETIQUETAS!

Todos los letreros, etiquetas y adhesivos deben ser claramente legibles y estar en buenas condiciones. Pueden comprarse etiquetas de repuesto del fabricante.

4. ¡MANTENGASE ALEJADO DE PIEZAS GIRATORIAS!

Mantenga las manos, brazos y dedos alejados de todas las piezas rotatorias o en movimiento. Desconecte siempre la máquina antes de intentar ningún ajuste que requiera entrar en contacto con la máquina o sus accesorios.

5. ¡ASEGURE LA ROPA SUELTA Y JOYERÍA!

La ropa suelta, joyería, pelo largo y sin atar pueden engancharse en las partes rotatorias de las máquinas. Usted puede reducir grandemente las oportunidades de un accidente asegurando estas cosas o despojándose de ellas.

6. ¡MANTENGA LIMPIA EL AREA DE TRABAJO!

Asegúrese de mantener el área de trabajo libre de obstáculos y materiales no esenciales. Si es posible permita solamente el acceso al área a aquellas personas directamente asociadas con el trabajo que se está realizando.

USE SIEMPRE EQUIPO PROTECTOR:

	AVISO Debe usarse protección ocular resistente al impacto mientras se opere o trabaje cerca de esta herramienta.
--	--

	PRECAUCION e requiere en todo momento protección auditiva personal cuando opere o trabaje cerca de esta herramienta.
--	--

	PRECAUCION Algunos individuos son susceptibles a desórdenes de brazos y manos cuando son sometidos a tareas que llevan consigo movimientos alta-mente repetitivos y/o vib-ración. Desórdenes tales como el síndrome del túnel carpiano y ten-donitis pueden ser causados o agravados por esfuerzos repetitivos y energicos de las manos y brazos.
--	---

INDICAZIONI PER LA SICUREZZA D'USO

I

Fin dal 1883, la EH Wachs si è guadagnata una reputazione per quanto riguarda qualità e impegno nella soddisfazione dei clienti. In questa ottica, alla Wachs dobbiamo anche assumerci la responsabilità di fare del nostro meglio per garantire la massima sicurezza d'uso dei nostri apparecchi. Abbiamo preparato un elenco di avvisi di sicurezza come ausilio nel creare il più sicuro ambiente di lavoro possibile. Raccomandiamo di seguire attentamente le precauzioni elencate.



Leggere attentamente quanto segue prima di proseguire.

INDOSSARE SEMPRE INDUMENTI PROTETTIVI:

1. LEGGERE IL MANUALE D'USO!!

Leggere le istruzioni per la messa a punto e l'uso prima di iniziare la messa a punto per risparmiare tempo prezioso e prevenire lesioni e danni al macchinario.

2. CONTROLLARE LA MACCHINA E GLI ACCESSORI!

Prima di mettere a punto la macchina, controllare sia la macchina che gli accessori. Verificare che le slitte portautensili non siano consumate, che i bulloni e i dadi non siano allentati, che non vi siano perdite di lubrificante, ruggine eccessiva, ecc. Una macchina ben mantenuta può ridurre notevolmente le possibilità di danni.

3. LEGGERE SEMPRE TARGHETTE ED ETICHETTE!

Tutte le targhette, le etichette e gli adesivi devono essere chiaramente leggibili e in buone condizioni. Si possono acquistare etichette di ricambio presso il produttore.

4. NON AVVICINARSI A PARTI IN MOVIMENTO!

Tenere mani, braccia e dita ben lontane da tutte le parti in movimento. Spegnerne sempre la macchina prima di effettuare regolazioni che richiedono il contatto con la macchina o i suoi accessori.

5. FISSARE INDUMENTI E GIOIELLERIA!

Indumenti larghi, gioielli pendenti o lunghi; capelli lunghi sciolti possono rimanere incastrati nelle parti rotanti sulle macchine. Fissandoli o rimuovendoli si può ridurre notevolmente il rischio di lesioni.

6. MANTENERE L'AREA DI LAVORO SGOMBRA!

Mantenere l'area di lavoro sgombra da materiale non essenziale. Se possibile, consentire l'accesso solamente al personale direttamente interessato nel lavoro svolto.

	ATTENZIONE Indossare occhiali di sicurezza resistenti all'urto durante l'uso di questo strumento o quando si lavora in sua prossimità.
--	--

	AVVERTENZA Indossare sempre protezione auricolare durante l'uso di questo strumento o quando si lavora in sua prossimità.
--	---

	AVVERTENZA Alcuni individui possono soffrire disturbi alle mani e alle braccia nell'esecuzione di mansioni che comportino movimenti alta-mente ripetitivi e/o vibrazione. Disturbi quali la sindrome del tunnel carpale e tendiniti possono essere causati o aggravati da sforzi ripetuti delle mani e delle braccia.
--	---

VEILIGHEIDSRICHTLIJNEN

N

Sinds 1883 heeft de firma E.H.Wachs een reputatie opgebouwd voor kwaliteit en heeft zich geëngageerd om voldoening te schenken aan de gebruiker. Dienovereenkomstig heeft E.H.Wachs de bijkomende verantwoordelijkheid op zich genomen het uiterste te betrekken om het gebruik van onze apparatuur onder de meest veilige omstandigheden te verzekeren.

We hebben een lijst samengesteld van veiligheidsaanbevelingen teneinde de meest veilige werkomgeving te scheppen.



We raden aan de hierondervermelde voorzorgsmaatregelen stipt na te leven. Lees het volgende aandachtig vooraleer verder te gaan.

1. LEES HET BEDIENINGSHANDBOEK!

Lees de opstel- en bedieningsrichtlijnen vooraleer met de opstelwerkzaamheden te beginnen om kostbare tijd te besparen en om persoonlijke letsels en schade aan de machines te voorkomen.

2. INSPECTEER DE MACHINE EN TOEBEHOREN

Vooraleer de machine op te stellen, inspecteer de machine en haar toebehoren. Kijk uit voor versleten gereedschapsleden, losse bouten en moeren, olie lekken, overmatige roest, enz.. Een goed onderhouden machine kan de kans voor kwetsuren aanzienlijk verminderen.

3. LEES ALTIJD DE PLAKKAATEN EN ETIKETTEN

Alle plakkaaten, etiketten en zelfklevers moeten duidelijk leesbaar zijn en in goede staat. Vervangingsetiketten kunnen bij de fabrikant gekocht worden.

4. HOUD AFSTAND VAN DRAAIENDE ONDERDELEN

Houd handen, armen en vingers weg van alle draaiende of bewegende onderdelen. Schakel de machine uit vooraleer afregelingen te verrichten die contact vereisen met de machine of haar toebehoren.

5. VERMIJD LOSSE KLEDING EN SIERADEN

Los zittende kleding, sieraden, en lang los haar kunnen door draaiende machineonderdelen gegrepen worden. Door ze vast te maken of ze te verwijderen kunt u de kans op verwondingen aanzienlijk verkleinen.

6. HOUD DE WERKRUIMTE VRIJ

Zorg ervoor dat de werkruimte vrij is van rommel en onnodige materialen. Toegang tot de werkruimte moet indien mogelijk enkel verleend worden aan personen die direct betrokken zijn bij het uit te voeren werk.

DRAAG ALTIJD BESCHERMENDE UITRUSTING

WAARSCHUWING

Een veiligheidsbril moet gedragen worden bij het bedienen van dit gereedschap of bij het werken in de buurt van dit gereedschap.

VOORZICHTIG

Persoonlijke gehoorbeschermer is aangeraden bij het bedienen van dit gereedschap of bij het werken in de buurt van dit gereedschap.

VOORZICHTIG

Sommige personen zijn vatbaar voor hand-en armlletsels wanneer zij blootgesteld zijn aan trillingen of handelingen die hoogst repetitieve bewegingen vergen. Letsels zoals Carpal tunnel syndroom en tendinitis kunnen veroorzaakt worden of verergeren door repetitieve krachtinspanningen van handen en armen.

SÄKERHETSANVISNINGAR

S

EH Wachs har sedan 1883 etablerat ett gott anseende när det gäller kvalitet och kundtillfredsställelse. Wachs känner sig därför förpliktad att göra sitt yttersta för att garantera såkrast möjliga användning av Wachs-utrustning.

Vi har ställt samman en lista av säkerhetsanvisningar som ett led i vår strävan att skapa såkrast möjliga arbetsmiljö. Vi rekommenderar att de försiktighetsåtgärder som förtecknats följs noggrant.



Läs igenom nedanstående ordentligt innan du fortsätter.

1. LÄS IGENOM BRUKSANVISNINGEN!

Genomläsning av anvisningarna för klargöring och drift innan klargöringen påbörjas kan medföra en värdefull tidsbesparing och bidra till att person- och maskinskador undviks.

2. KONTROLLERA MASKINEN OCH DESS TILLBEHÖR!

Kontrollera maskinen och besiktiga dess tillbehör. Se efter om verktygshållare är slitna, skruvar och muttrar lösa, smörjmedel läcker, kraftigt rost förekommer o.d. En korrekt underhållen maskin medför kraftigt minskad risk för personskador.

3. LÄS ALLTID SKYLTA OCH ETIKETTER!

Alla skyltar och etiketter måste vara helt läsliga och i gott skick. Utbytesetiketter kan inköpas från tillverkaren.

4. HÅLL DIG BORTA FRÅN Roterande DELAR!

Håll händer, armar och fingrar borta från roterande eller rörliga delar. Slå alltid av maskinen innan justering som kräver kontakt med maskinen eller dess tillbehör utförs.

5. STOPPA IN LÖST SITTANDE KLÄDER OCH SMYCKEN!

Löst sittande kläder och smycken samt långt, hängande hår kan fastna i maskinens roterande delar. Genom att säkra dessa eller avlägsna kläder och smycken kan du minska risken för skador avsevärt.

6. HÅLL ARBETSSTÄLLET RENT!

Vår noga med att hålla arbetsstället fritt från skräp och ej behövligt material. Ge om möjligt tillgång till arbetsstället endast till personal som är direkt inbegripna i det arbete som utförs.

ANVÄND ALLTID SKYDDSRUSTNING:

VARNING!

Stötsäkra skyddsglasögon måste bäras vid användning av eller arbete nära detta redskap.

OBS!

Hörselskydd krävs alltid vid användning av eller arbete nära detta redskap.

OBS!

Vissa personer är känsliga för de effekter som kan uppstå i händer och armar när de utför rörelser som är i hög grad repetitiva och/eller utsatta för vibrationer. Tillstånd såsom karpal tunnel syndrom och seninfiammation kan orsakas eller förvärras om händer och armar används för att utföra repetitivt och ansträngande arbete.

INSTRUÇÕES DE SEGURANÇA

P

Já desde 1883 que a EH Wachs tem vindo a criar uma reputação de qualidade e um compromisso de satisfação dos consumidores. Nesta linha de conduta, a Wachs tem que assumir a acrescida responsabilidade de fazer o seu melhor para garantir a máxima segurança na utilização dos nossos equipamentos.

Acabámos de compilar uma lista de lembretes de segurança destinados a ajudar na criação de um ambiente de trabalho o mais seguro possível. Aconselhamos que sejam observadas com todo o cuidado as várias fases precauções descritas a seguir.



Ante de continuar, leia com o máximo cuidado o que vai a seguir

1. Leia o Manual de Operações!

A leitura das instruções de montagem e de funcionamento antes de iniciar os procedimentos de montagem poderá poupar um tempo precioso e prevenir ferimentos no operador ou danos nas máquinas.

2. Inspeccione a máquina e respectivos acessórios!

Antes de efectuar a sua montagem, faça uma inspeção física da máquina e seus acessórios. Dirija a sua busca para peças desluzadas já usadas, parafusos e porcas soltos, derrame de lubrificantes, ferrugem excessiva, etc. A manutenção adequada do maquinismo diminuirá os riscos de ferimentos.

3. Leia sempre os cartazes e as etiquetas!

Todos os cartazes, etiquetas e autocolantes deverão ser claramente legíveis e estar em perfeitas condições. Etiquetas acessórias de substituição poderão ser encomendadas directamente do fabricante.

4. Mantenha-se fora do alcance de peças rotatórias!

Mantenha as mãos, braços e dedos fora do alcance de todas as peças rotatórias ou em movimento. Desligue, primeiro, a máquina sempre que tiver de proceder a ajustamentos que requirem contacto com a máquina ou com as suas peças.

5. Aperte bem a roupa folgada e peças de joalheria!

Roupas folgadas, joalheria e cabelo solto e comprido poderão ser apanhados pelas peças rotatórias das máquinas. Manter estes artigos amarrados ou desfazer-se deles será a melhor maneira de reduzir a possibilidade de ferimentos.

6. Mantenha livre a área de trabalho!

Procure manter a área de trabalho livre de ajuntamentos e de materiais não essenciais. O acesso a essa área só deverá ser permitido ao pessoal directamente envolvido no trabalho que estiver a ser executado, tanto quanto possível.

USE SEMPRE EQUIPAMENTO DE PROTECÇÃO:

AVISO!

Sempre que trabalhar com esta ferramenta ou perto dela deverá usar uma protecção para a vista, à prova de choque.

CUIDADO!

É obrigatório usar protecção individual para os ouvidos durante todo o tempo que trabalhar com esta ferramenta ou perto dela.

CUIDADO!

Há pessoas que são propensas a sofrer certos sintomas nas mãos ou nos braços quando expostos a tarefas que envolvam movimentos altamente repetitivos, acompanhados ou não de vibrações. Sintomas como, por exemplo, o síndrome do túnel do carpo e a tendinite poderão ser causados ou agravados pelo uso esforçado e repetitivo das mãos e dos braços.

TURVALLISUUSOHJEET

FIN

EH Wachs on tunnettu korkeasta laadusta ja tyytyväisistä asiakkaistaan jo vuodesta 1883. Wachs huolehtii myös siitä, että laitteen käyttö on mahdollisimman turvallista.

Olemme koonneet tähän turvallisuutta koskevan muistilistan, jota noudattamalla työympäristöstä saadaan mahdollisimman turvallinen. Kehotamme noudattamaan tässä esiteltyjä varoimenpiteitä huolellisesti.



Lue seuraavat kohdat huolellisesti, ennen kuin jatkat.

1. LUE KÄYTTÖOHJEKIRJA!

Asennus- ja käyttöohjeisiin perehtyminen ennen asennuksen aloittamista säästää aikaa ja auttaa vähentämään tapaturmavaaraa ja koneiden vaurioitumisriskiä.

2. TARKASTA KONE JA LISÄLAITTEET!

Ennen kuin aloitat asennuksen, tarkasta kone ja lisälaitteet. Varmista, että teräkelkat eivät ole kuluneet, pulteja ja muttereita ei ole löysällä, voiteluainetta ei vuoda, konessa ei ole liikaa nostetta jne. Hyvässä kunnossa pidetty kone voi vähentää tapaturmavaaraa huomattavasti.

3. LUE KAIKKI KILVET JA MERKINNÄT!

Kaikkien kilpien, merkintöjen ja tarrojen on oltava selkeästi luettavissa ja hyvässä kunnossa. Vaihottarvoja voit ostaa valmistajalta.

4. PYSYTTÄÄ ETÄÄLLÄ PYÖRIVISTÄ OSISTA!

Pidä kädet, käsivartret ja sormet loitolla kaikista pyörivistä tai liikkuvista osista. Kytke kone aina pois päältä ennen kuin suoritat säätöjä, joissa joudut koskemaan koneeseen tai sen lisälaitteisiin.

5. SIDO LÖYSÄT VAATTEET JA HIUKSET KIINNI!

Löysät vaatteet, korut ja pitkät hiukset voivat takertua koneen pyörivien osiin. Vähennät tapaturmavaaraa huomattavasti, kun poistat tai sidot kiinni löysät vaatteet ja korut ja sidot hiukset kiinni.

6. PIDÄ TYÖSKENTELYALUE SIISTINÄ!

Varmista, että työskentelyalueella ei ole roskia eikä tarpeetonta materiaalia. Päästä työskentelyalueelle vain käsillä olevaan työhön osallistuvia henkilöitä, mikäli mahdollista.

KÄYTÄ AINA SUOJAVÄLINEITÄ:

VAROITUS

Käytä iskunkestäviä suojalaseja, kun käytät tätä työkalua tai työskentelet sen lähellä.

HUOMAA

Kuulosuojainten käyttöä vaaditaan aina, kun käytät tätä työkalua tai työskentelet sen lähellä.

HUOMAA

Pitkään jatkuva altistuminen toistuvalla liikkeellä ja/tai tärinällä voi aiheuttaa käsiin ja käsivarsien sairauksia joillekin henkilöille. Käsiin ja käsivarsiin kohdistuva toistuva ja voimakas liike voi aiheuttaa tai pahentaa sairauksia kuten ranneknavaoireyhtymä ja jännetulehdus.

Siden 1883 har EH Wachs haft ry for deres kvalitet og varetagelse af kundtilfredshed og vil også gøre vort bedste for at sikre, at vore maskiner benyttes på en sikker og forsvarlig måde.

Vi har lavet en liste over påmindelser, der skal bidrage til at skabe det sikrest mulige arbejdsmiljø. Vi anbefaler, at sikkerhedsforanstaltningerne på listen omhyggeligt overholdes.



Læs følgende grundigt, inden der foretages andet

1. LÆS BRUGSANVISNINGEN!!

Hvis man læser anvisningerne i klargøring og drift, inden man begynder at gøre maskinen klar, kan man spare tid og forhindre person- og maskinskade.

2. INSPICÉR MASKINE OG UdstYr!

Inden maskinen gøres klar, skal man inspicere maskinen og udstyret. Se efter slidte fittings, løse bolte og møtrikker, olie-lækager, rust osv. Når maskinen holdes i god stand, er der langt mindre risiko for personskade.

3. LÆS ALTID SKILTE OG ETIKETTER!

Alle skilte og etiketter skal være letlæselige og i god stand. Nye skilte og etiketter fås hos forhandleren.

4. HOLD AFSTAND TIL BEVÆGELIGE DELE!

Hold hænder, arme og fingre væk fra alle roterende og bevægelige dele. Man skal altid slukke for maskinen, inden man påbegynder justering, hvor man kommer i kontakt med maskinen eller udstyret.

5. BRUG IKKE LØSTHÆNGENDE TØJ OG SMYKKER!

Løsthengende tøj, smykker og langt, løsthengende hår kan blive fanget i maskinens bevægelige dele. Man kan i høj grad nedsætte risikoen for personskade ved ikke at bruge løsthengende tøj og smykker og ved at samle langt hår oppe på hovedet.

6. HOLD ARBEJDSSTEDET RYDDET!

Arbejdsstedet skal holdes ryddeligt og fri for materialer, der ikke hører til. Uvedkommende personer bør ikke have adgang til arbejdsstedet, hvis det er muligt.

BRUG ALTID BESKYTTELSESDUSTYR:

	ADVARSEL Man skal bruge slag-resistente sikkerhedsbriller, når man arbejder med eller i nærheden af denne maskine.
---	--

	FORSIGTIG Man skal altid bruge høreværn, når man arbejder med eller i nærheden af denne maskine.
---	--

	HUOMAA Nogle mennesker er disponeret for lidelser i hænder og arme, når de udsættes for opgaver, der involverer stærkt repetitiv bevægelse og/eller vibration. Sygdomme, såsom karpaltunnelsyndrom og ten-dinitis, kan forårsages eller forværres af repetitiv, kraftig brug af hænder og arme.
---	---

Από το 1883, η EH Wachs έχει δημιουργήσει μια φήμη ποιότητας και δέσμευσης στην καινοποίηση του πελάτη. Συνεπώς, η Wachs πρέπει να αναλάβει την προοβητική υποχρέωση να κάνουμε το καλύτερο για να εξασφαλίσουμε την ασφαλέστερη χρήση του εξοπλισμού μας.

Έχουμε καταρτίσει έναν κατάλογο υπομνήσεων ασφαλείας που βοηθούν στη δημιουργία του ασφαλέστερου δυνατού χώρου εργασίας. Συστάουμε την πιστή εφαρμογή των προληπτικών μέτρων που αναγράφονται παρακάτω.

Πριν προχωρήσετε διαβάστε όλες τις παρακάτω υποδείξεις

1. ΔΙΑΒΑΣΤΕ ΤΟ ΒΙΒΛΙΟ ΟΔΗΓΩΝ!

Η ενάντιση των οδηγίων εγκατάστασης και χειρισμού πριν αρχίσετε τις διαδικασίες εγκατάστασης μπορούν να σας εξοικονομήσουν πολύτιμο χρόνο και να βοηθήσουν στην αποτροπή τραυματισμού των χειριστών ή βλάβης των μηχανών.

2. ΕΠΙΘΕΩΡΗΣΤΕ ΤΗ ΜΗΧΑΝΗ ΚΑΙ ΤΑ ΕΞΑΡΤΗΜΑΤΑ!

Πριν από την εγκατάσταση της μηχανής επιθεωρήστε τη φυσική κατάσταση της μηχανής και των εξαρτημάτων. Κοιτάξτε για τυχόν φθορά στις γλίστρες των καναλιών, λασκαρισμένα μπουλόνια ή παξιμάδια, διαρροή λιπαντικού, υπερβολική σκουριά κτλ. Η μηχανή που συντηρείται κανονικά μπορεί να μειώσει σημαντικά τις πιθανότητες τραυματισμού.

3. ΠΑΝΤΑ ΔΙΑΒΑΣΤΕ ΤΙΣ ΠΙΝΑΚΙΔΕΣ & ΤΙΣ ΕΤΙΚΕΤΕΣ!

Όλες οι πινακίδες, ετικέτες και αυτοκόλλητα πρέπει να διαβάζονται καθαρά και να βοσκοτούν σε καλή κατάσταση. Εφεδρικές ετικέτες μπορείτε να αγοράσετε από τον κατασκευαστή.

4. ΑΠΟΜΑΚΡΥΝΘΕΙΤΕ ΑΠΟ ΤΑ ΠΕΡΙΣΤΡΕΦΟΜΕΝΑ ΕΞΑΡΤΗΜΑΤΑ!

Κρατήστε χέρια, βραχίονες, και δάχτυλα μακριά από όλα τα περιστρεφόμενα ή κινούμενα εξαρτήματα. Πάντοτε σβήνετε τη μηχανή πριν επιχειρήσετε οποιαδήποτε ρύθμιση που απαιτεί επαφή με τη μηχανή ή τα εξαρτήματά της.

5. ΜΑΖΕΨΤΕ ΤΑ ΛΥΤΑ ΡΟΥΧΑ & ΚΟΣΜΗΜΑΤΑ!

Τα ρούχα που δεν έχουν καλή εφαρμογή, τα κοσμήματα, τα μακριά, λυτά μαλλιά μπορεί να προστούν στα περιστρεφόμενα εξαρτήματα της μηχανής. Στερεώνοντας ή βγαζόντάς τα μπορείτε να μειώσετε σημαντικά την πιθανότητα τραυματισμού.

6. ΔΙΑΤΗΡΕΙΤΕ ΕΛΕΥΘΕΡΟ ΤΟ ΧΩΡΟ ΕΡΓΑΣΙΑΣ!

Φροντίστε να διατηρείτε το χώρο εργασίας ελεύθερο από ακαταστάσια και επισπασμένα υλικά. Επιτρέψτε την είσοδο μόνο στους έχοντες άμεση σχέση με την εκτελούμενη εργασία αν είναι δυνατό.

ΝΑ ΦΟΡΑΤΕ ΠΑΝΤΟΤΕ ΠΡΟΣΤΑΤΕΥΤΙΚΑ ΕΙΔΗ:

	ΠΡΟΕΙΔΟΠΟΙΗΣΗ Να φοράτε ειδή προστασίας των ματιών κατά της πρόσκρουσης όταν χειρίζεστε ή εργάζεστε κοντά στο εργαλείο αυτό.
---	--

	ΠΡΟΣΟΧΗ Χρειάζεται πάντοτε ατομική προστασία των αυτιών όταν χειρίζεστε ή εργάζεστε κοντά στο εργαλείο αυτό.
---	--

	ΠΡΟΣΟΧΗ Μερικά άτομα είναι ευαίσθητα στις διαταραχές των χεριών και των βραχιόνων όταν εκτελούνται σε εργασίες που συνεπάγονται εξαιρετικά επαναληπτικές κινήσεις και/ή κραδασμούς. Οι διαταραχές όπως το σύνδρομο καρπικής σπράγγας και η τενοντίτιδα μπορεί να προκληθούν ή να επιδεινωθούν από τις επαναληπτικές, ισχυρές εκπτώσεις των χεριών και των βραχιόνων.
---	--

TSE TUBE SQUARING MACHINE

SECTION III

EC Declaration of Conformity

Name and address of manufacturer (if different) E.H. Wachs Company
100 Shepard St.
Wheeling, Il. 60090 USA

Distributed in the EC by: _____
Business address: _____

We declare that the machine described below conforms with the EHSR of the machinery directive 89/392/EEC and amendments 91/368/EEC, 93/44/EEC and 93/68/EEC

Machine Title Tube and Fitting Squaring Machines

Model Number TSE / FSE 18-000-01 thru 18-000-08
TFS 19-000-01 thru 19-000-26

Machine Description Portable machinery to face / square tube &
pipe ends for weld preparation

Serial Number _____

Harmonized Standards Used EN 50144, EN 55014, HD 400, EN 292, EN
292-2, EN 294, EN 394

Other Safety Standards Used PR: EN 982, PR: EN 983, 10/95
PR: EN 792-1, PR: EN 1050

Name of person authorized to sign on behalf of the E.H. Wachs Companies Rodger P. Soeldner

Position Vice President / CFO

Signature 

Date July 15, 1997

TSE TUBE SQUARING MACHINE

SECTION IV

TSE SPECIFICATIONS

The new **Wachs TSE 1.0** is a light-weight, hand held, portable tool for precision cutting of square, burr-free faces on tubing from 1/8" through 1" O.D.

Featuring a unique hand twist clamping system, utilizing spring loaded plastic Delrin[®] collets which grip the tube firmly yet do not mar the tubing wall!

The TSE 1.0 utilizes a trigger activated variable speed electric motor. The cutting tool is conveniently infed by rotating the cutter spindle knob. It is equipped with an infeed "Micrometer" index gauge for precise machining operations, giving the operator excellent control when material removal is critical to maintain tubing lengths.

The TSE 1.0 offers fast production operation plus easy handling, improved finishes and consistent cuts. It's ideal for contractors, fabricators and maintenance departments, especially where automatic welding is employed.



Machining Capacity:	1/8" thru 1" O.D.
Machining Function:	Burr-free squaring/facing
Machining Materials:	Stainless steel/High alloy
Wall Thickness:	.015" thru .120"
Clamping System:	Stainless steel collets with hand locking nut
Clearance Radius:	1-1/2" From Centerline
Tool Advance:	Hand advanceable & retractable spindle with indice gauge (.245" per revolution)
Controls:	ON/OFF Variable speed trigger switch.
Tooling:	Titanium Nitrate coated form tools
Tool RPM:	0-600 Variable.
Feed System:	Manual advance with index gauge
Drive Motors:	Milwaukee or Metabo, 110 volt or 220 volt
Axial Feed:	.400" max
Weight:	8 lbs.
Finish:	Hard anodized and Stainless steel

Machine Model	Average Sound Level(Decibels)	Maximum Sound Level(Decibels)
TSE	80dBA	90dBA

TSE TUBE SQUARING MACHINE

SECTION V.

SET UP & OPERATING INSTRUCTIONS

TSE TUBE SQUARING MACHINE

SECTION V

TSE SET UP & OPERATING PROCEDURES

General Tool Components:

- A. **COLLET NUT**- Used for locking workpiece.
- B. **TOOL SPINDLE**- Holds tool bit.
- C. **MICROMETER GAUGE**- Used to determine length and depth of cut.
- D. **FEED NUT**- Turn this knob to advance tool.
- E. **HANDLE**- Use to gain better leverage while tensioning Collet Nut

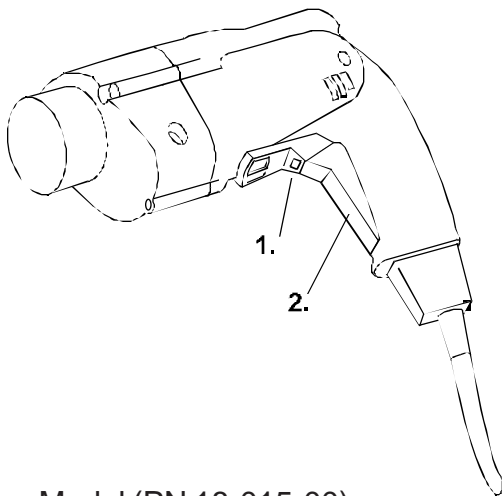
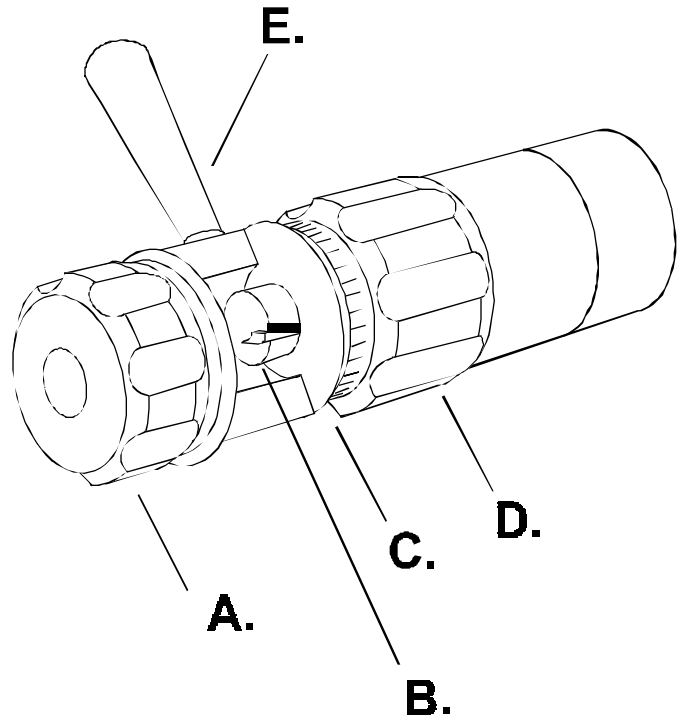

Milwaukee Model (PN 18-015-00)

- 1. **THROTTLE LOCK**-Locking mechanism for motor.
- 2. **THROTTLE**- Squeeze trigger to release throttle lock.

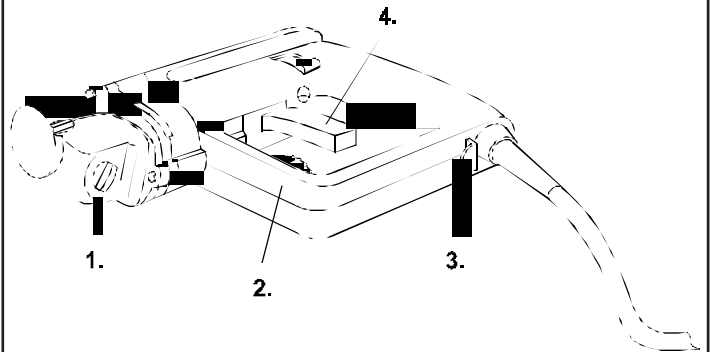

Metabo Model (PN 30-031-00)

- 1. **SPEED RANGE SELECTOR**-High or low speed.
- 2. **DIAL SPEED CONTROLLER**- Dial in chosen motor speed.
- 3. **THROTTLE LOCK**-lock "ON" mechanism for motor.
- 4. **THROTTLE TRIGGER**-Squeeze to release throttle lock.

NOTE: Please refer to your Operator Manual for further details regarding the operation of your Milwaukee or Metabo drill.

TSE TUBE SQUARING MACHINE

SECTION V

TSE SET UP & OPERATING PROCEDURES (cont.)

A. Collet Selection and Installation / Removal

1. Select collet set, reference selection chart on page 10.
2. Remove collet lock nut. Rotate counter clockwise (Figure 1).



Fig. 1

3. Place collet assembly into tapered bore. (Fig. 2)



Fig. 2

4. Reinstall lock nut. Rotate clockwise until retaining groove on collet snaps over inner dia. lip of lock nut. (Fig. 3)



Fig. 3

5. To remove collet, tighten lock nut fully. Press collet sections in and toward center. Remove lock nut and collet assembly.

B. Workpiece Clamping

1. Loosen lock nut and collet by turning counter clockwise.
2. Slide workpiece through collet. Do not damage tool if installed.
3. Tighten lock nut. Turn clockwise until workpiece is held firmly.
4. Remove workpiece by turning lock nut counter clockwise roughly 1/3 to 1/2 turn.

C. Tool Bit Installation



CAUTION: Unplug machine from power source before installing or changing tool bits.

1. Place tool bit into tool slot. Position for desired work dia. Check tool bit alignment with end of tube. Tool should be as far from center as possible. (Fig.4)
2. Tension locking screws with 1/8" allen key.

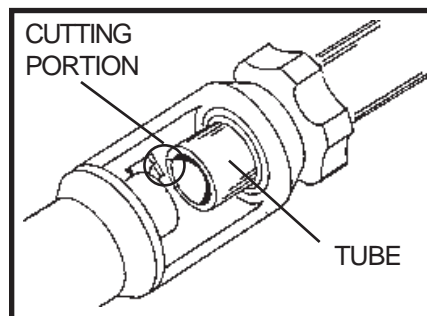

Fig. 4

D. Drive Motors for the TSE

1. Motors for TSE: Milwaukee has simple variable speed trigger. Metabo has variable speed trigger, "ON" position lock, dial speed control; electronic load sensing speed stabilization (please refer to illustrations on preceeding page for exact location of components).

TSE TUBE SQUARING MACHINE

SECTION V

TSE SET UP & OPERATING PROCEDURES (cont.)

E Machining Instructions



CAUTION: Keep hands clear of cutting tool during operation.

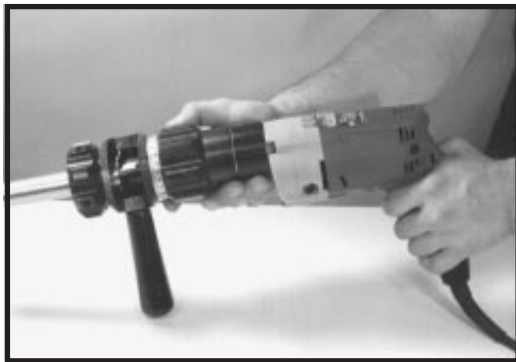
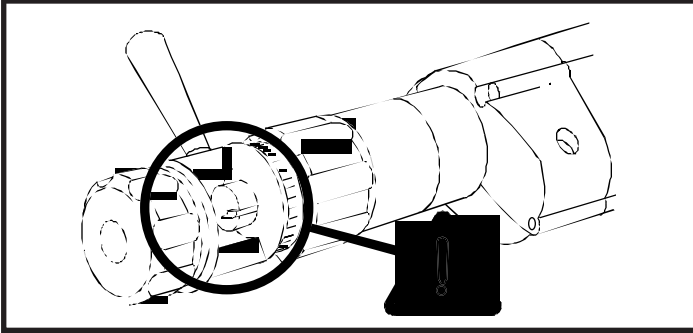

Figure 5

1. Begin rotation. Squeeze trigger to obtain desired speed.
2. Feed is controlled by rotating feed knob. (Figure 5)
3. Index marks on feed knob indicate tool advance.

F. Machining Tips

1. For precision machined lengths leave motor off. Rotate feed knob until tool touches end of work. Note location on index gauge. Retract feed knob. Add required measurement to observed number on feed knob. With power on, monitor index gauge. Length accuracy: to $\pm .002$ ".
2. Be careful of cutting edge of tool bit. Edge is sharp and can be damaged.
3. Check tool bit often. If work edge develops burr, tool bit may be worn.
4. Keep consistent pressure on feed knob.
5. To break off long chips, retract feed knob for a moment and return to feeding.



CAUTION: Metal residue created by blade is very sharp. Use caution when handling.

6. "Chatter" can be controlled by changing feed rate of tool. Increasing feed and reducing speed will solve this problem.

G. Bench Stand Removal & Setup

1. To remove stand, loosen 1/2-13 x 2-1/2" FHCS. To reinstall stand, slide FHCS through base plate and support. Thread FHCS into TSE main housing and tighten.

SECTION VI

TSE MAINTENANCE



CAUTION: Unplug machine from power source before performing any service.

TSE maintenance consists of cleaning and inspection for damage and wear. No grease required for clamping system. Cutter head bushing should be checked for looseness. Feed nut and thrust bearing should be checked for end float. Check power cord for wear.

SECTION VII

**OPERATIONAL
CHARTS
&
GRAPHS**

TSE TUBE SQUARING MACHINE

SECTION VII

TSE CHARTS & GRAPHS

TSE COLLET SELECTION CHART	
*Standard American Sizes	
Part No.	Workpiece O.D.
18-404-00	.125"
18-404-01	.188"
18-404-02	.250"
18-404-04	.375"
18-404-06	.500"
18-404-08	.625"
18-404-10	.750"
18-404-14	1.00"

TSE COLLET SELECTION CHART	
*Standard Metric Sizes	
Part No.	Workpiece O.D.
18-404-36	6 mm
18-404-38	8 mm
18-404-40	10 mm
18-404-42	12 mm
18-404-44	14 mm
18-404-46	16 mm
18-404-48	18 mm
18-404-50	20 mm
18-404-55	25 mm

* Standard sizes in stock. Other sizes made on special order.

** All collets are marked with workpiece O.D. sizes.

TOOLING SELECTION CHART

Part No.	Work Material	Finish	Packaged as:
18-701-00	300 Stainless Steel	Uncoated	Individual
18-701-01	300 Stainless Steel	Zirconium Nitrite	Box of 10 pcs.
18-701-02	300 Stainless Steel	Titanium Nitrite	Box of 10 pcs.
18-701-03	300 Stainless Steel	Uncoated	Box of 10 pcs.
18-701-04	*Exotic hard Material*	Uncoated	Individual

* Exotic Hard Material: Inconel, Hastelloy, etc.

** Custom Tool Bits Available as special Order

TSE TUBE SQUARING MACHINE

SECTION VIII

TSE TROUBLE SHOOTING

Trouble	Possible Cause	Remedy
Machine Won't Run	Power Unit Not Connected	Check Power Cord & Connection
Work Piece Shifts Under Cutting Load	Loose Collet Lock Nut	Tension Collet Lock Nut
Poor Workpiece End Quality	Dull or Chipped Tool Bit	Replace Tool Bit
Machine Chatters During Cut	RPM Speed of Tool Head	Refer to Section on Machining Tips is Set Too Fast or Feed Rate is Too Light
Chip Runs Up Workpiece I.D.	Improper Tool Bit Installation	Refer to Tool Bit Installation Procedure (Section 5)

TSE TUBE SQUARING MACHINE

SECTION IX

PARTS LISTS & EXPLODED VIEW DRAWINGS

TSE TUBE SQUARING MACHINE

TSE 1.0 110 & 220 Volt Bill of Material

18-000-01 Milwaukee 110v, # 18-000-02 Milwaukee 220v, # 18-000-05 Metabo 110v, # 18-000-06 Metabo 220v

Ref. #	Part #	Qty.	Description
001	18-001-00	1	Housing, Main
002	18-002-00	1	Ring, Feed
003	18-003-00	1	Nut, Feed
004	18-073-00	1	Nut, Collet
005	18-005-00	1	Bushing, Feed
006	18-006-00	1	Coupling, Drive
007	18-007-00	1	Shaft, Drive
008	18-008-00	1	Spindle, Tool
009	18-009-00	1	Coupler
	18-012-00	1	Tool, Collet Lock (N/S)
	18-013-00	1	Label, Feed - Inches (N/S)
	18-013-01	1	Label, Feed - Metric (N/S)
	18-054-00	1	Plate, I.D. (N/S)
015	18-015-00	1	Motor, 110V (Milwaukee)
015	10-031-00	1	Motor, 220V (Milwaukee)
015	30-031-01	1	Motor, 110V (Metabo)
015	18-000-04	1	Motor, 220V (Metabo)
	19-034-00	1	Adaptor, Metabo (N/S)
016	18-016-00	1	Handle
017	18-017-00	Varies	Shim
018	18-018-00	1	Bearing, Flange
019	18-019-00	1	Bearing, Thrust
020	18-020-00	1	Bearing, Thrust
021	18-021-00	1	Bearing, Sleeve
	18-022-00	1	Nut, Allen 1/4-20 (N/S)
	18-701-00	1	Bit, Facing (N/S)
			Inch Size Collets
404	18-404-00	1	Collet - .125"
	18-404-01	1	Collet - .188"
	18-404-02	1	Collet - .25"
	18-404-04	1	Collet - .375"
	18-404-06	1	Colet - .5"
	18-404-08	1	Collet - .625"
	18-404-10	1	Collet - .75"
	18-404-14	1	Collet - .1"

Ref. #	Part #	Qty.	Description
			Metric Size Collets
	18-404-36	1	Collet - 6mm
	18-404-38	1	Collet - 8mm
	18-404-40	1	Collet - 10mm
	18-404-42	1	Collet - 12mm
	18-404-44	1	Collet - 14mm
	18-404-46	1	Collet - 16mm
	18-404-48	1	Collet - 18mm
	18-404-50	1	Collet - 20mm
	18-404-55	1	Collet - 25mm
071	18-071-00	1	"O" Ring, Thick
072	18-072-00	1	"O" Ring, Thin
	18-401-00	1	Storage case (N/S)
	18-402-00	1	Stand, Tse/Fse (N/S)
			Fasteners
1	90-027-03	1	Key, 1/8" Sq. x 3/8"
2	90-026-08	2	Pin, Dowel
3	90-046-58	2	Pin, Roll 3/16" x 5/8"
4	90-050-08	1	SHCS, 1/4-20 x 7/8" (N/S)
5	90-194-15	1	SSS, 1/2-13 x 1-1/2" ss
6	90-049-01	2	Screw, Drive (N/S)
7	90-054-05	2	SSS, 1/4-20 x 1/2" (N/S)
8	90-800-39	1	1/8" Allen "T" (N/S)

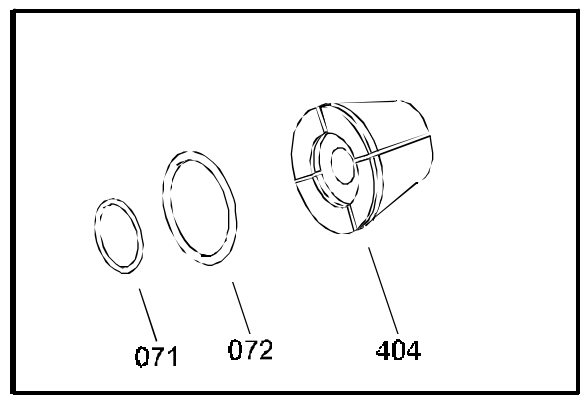
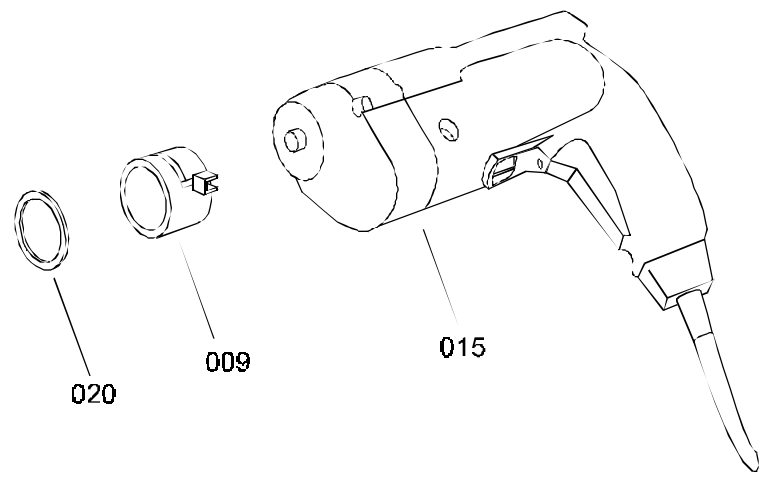
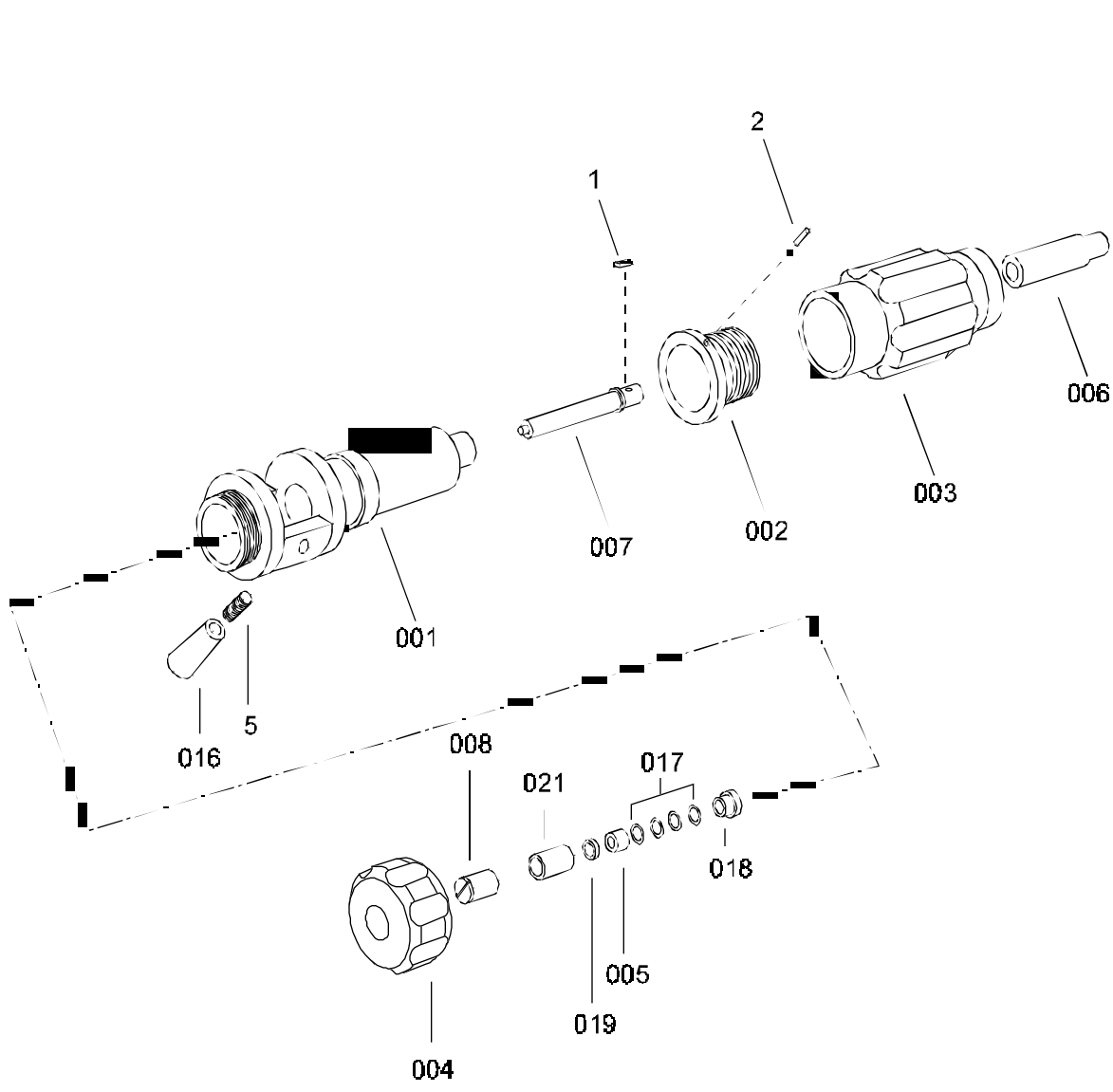

TSE TUBE SQUARING MACHINE

18-402-00, STAND, TSE AND FSE

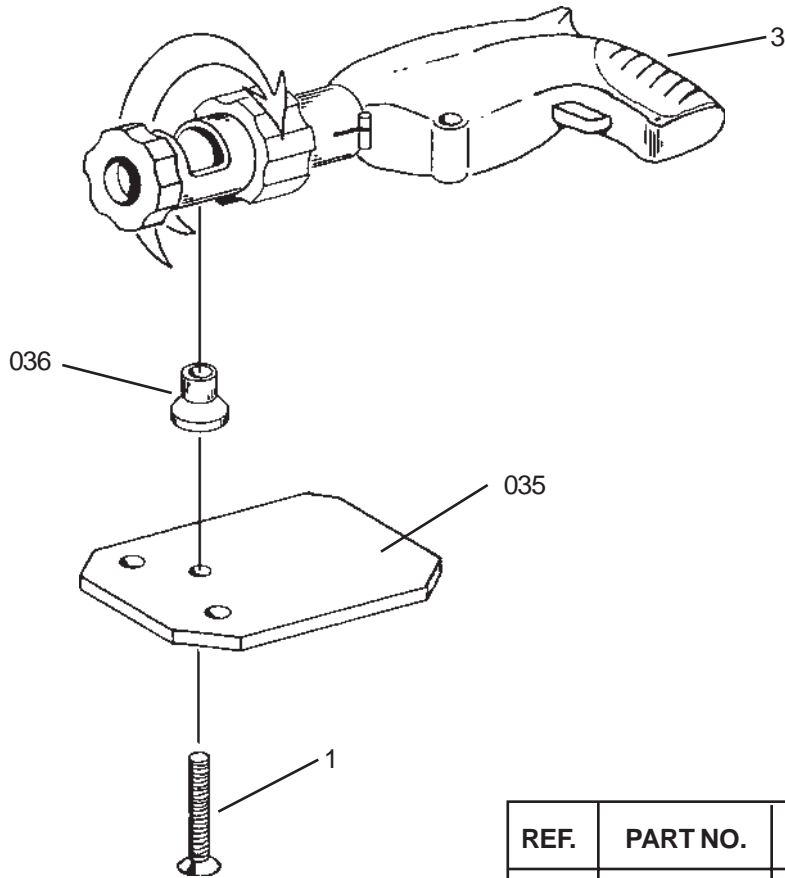

REF.	PART NO.	QTY.	DESCRIPTION
035	18-035-00	1	BASE, STAND
036	18-036-00	1	SUPPORT, STAND

FASTENERS

REF.	PART NO.	QTY.	DESCRIPTION
1	90-093-13	1	FHCS ½-13 x 2-½" LG
3	18-000-00	1	TSE/FSE

TSE TUBE SQUARING MACHINE

SECTION X

TSE ORDERING INFORMATION

To place an order or to get more detailed information on any E.H. Wachs products, call us at:
1-800-323-8185.

ORDERING REPLACEMENT PARTS

Please use parts list provided in manual. Have part description and part number of required replacement part or parts to help expedite order and insure proper parts are being ordered.

REPAIR INFORMATION

Please call E.H. Wachs Company prior to returning any equipment for repair. We will advise you of shipping and handling. Please enclose with equipment to be repaired your name, address, phone number and a brief description of problem or work to be done or estimated.

All repair work done at our plant will be estimated and the customer advised of cost and time required to complete repair.

WARRANTY INFORMATION

Enclosed with the manual is a warranty card. Please fill out the registration card and return to E.H. Wachs. Retain the owners registration record and warranty card for your information.

RETURN GOODS ADDRESS

E.H. Wachs Company
100 Shepard Street
Wheeling, Illinois 60090



Call or Write:

E.H. Wachs Company
P.O. Box A
100 Shepard Street
Wheeling, Illinois 60090

847-537-8800

FAX: 847-520-1147 • 847-520-1168

Toll-Free: 1-800-323-8185

	TUBE & PIPE
	SQUARING MACHINES 
Mod. TSE	Ser.No. <input type="text"/> <input type="text"/> <input type="text"/> <input type="text"/> <input type="text"/> <input type="text"/> <input type="text"/>

Enter Your Machines Serial Number Here For
Proper Record Keeping and Ordering Reference.